

Dr. Eddy™

Featuring FCI (Flow Characteristic Indicator) Technology

U.S. Patent No. 7,549,348

Operating Instructions

General

The Smartflow Dr. Eddy is a variable area liquid flow meter with four different scales. One scale is a conventional flow rate scale in either GPM or LPM. The remaining three scales are FCI (Flow Characteristic Indication) scales that indicate whether flow is laminar or turbulent depending on cooling passage size and water temperature. Each Dr. Eddy is equipped with a mechanical thermometer for determining inlet water temperature in Fahrenheit or Celsius units. This meter may be equipped with optional male and female disconnects or with optional brass end caps.

Operation

1. Connect the Dr. Eddy in a cooling circuit being sure that the flow direction corresponds to the flow arrow on the decal.
2. Using the thumbwheel on the rotating scale select the desired scale. The blue scale is a standard flow rate scale. Three FCI scales are provided for 1/4", 3/8" and 1/2" ID cooling passages.
3. Choose the FCI scale that most closely matches your cooling passage ID. Rotate the scale so it may be viewed as shown in Fig. 1. Here we have selected a cooling passage ID of 1/2".
4. Note the water temperature of 80°F on the thermometer as shown in Fig. 1.
5. Adjust the flow to match the 80°F line on the scale as shown in Fig. 1. With flow at this mark or higher Dr. Eddy predicts the flow in the cooling passage to be turbulent. Turbulent flow produces superior cooling results.
6. This same procedure may be applied to different water temperatures and cooling passage sizes to predict turbulent flow. Note that flow in the red lined zone is laminar at any water temperature and produces poor cooling results. Conversely, any flow in the green wavy lined zone is likely to be turbulent regardless of water temperature.

NOTE: Dr. Eddy is calibrated for use with water only. The presence of ethylene glycol significantly increases the rate of flow required for turbulence. Contact the factory for more information.

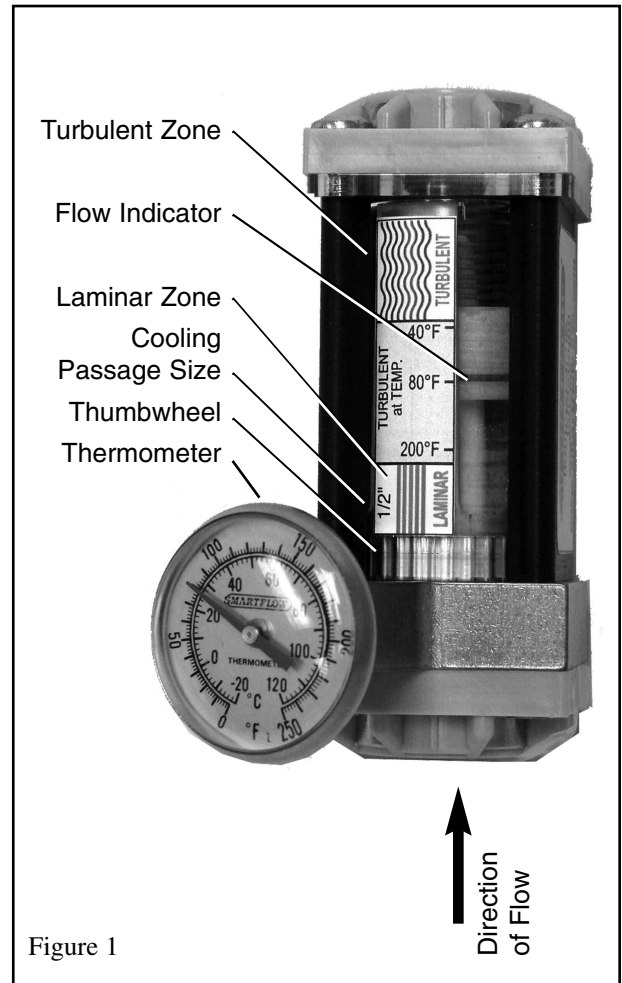

Figure 1

Specifications

Connection sizes.....1/4" or 3/8"
Operating Temperature.....210°F (99°C) max.
Operating Pressure100 psi (6.9 bar)
Accuracy.....±10%

Component Materials

End CapsBrass or
Glass-Filled Nylon
Viewing Body.....Polysulfone
Indicator Ring.....Silicone Rubber
Indicating FloatDelrin
Spring302 Stainless Steel
O-RingsEPDM
Cap ScrewsStainless Steel
Gauge Block.....Brass
Optional
Quick-Connect FittingsBrass

Cleaning

Debris in the circulating system may cause the indicating float inside the unit to stick or may discolor the inside wall of the polysulfone barrel. Contact Burger & Brown Engineering for replacement parts or repair service. Clean the flow meter as follows:

Warning! Do not clean any of the plastic parts with acetone or other aromatic hydrocarbon solvents. They will attack and destroy the plastic.

1. Remove the four 10-24 Screws in each corner.
2. Remove the two End Caps.
3. Remove the Brass Tee Block with Thermometer.
4. Remove the black Aluminum Wrapper and the Rotating Scale. Wipe clean with a soft cloth or paper towel.
5. Remove the Indicating Float and Spring. Clean gently with a soft cloth or paper towel. Do not bend or distort the SS spring.
6. Remove the white Polysulfone Torpedo by gently pressing on the tip.
7. Clean the Polysulfone Barrel with a soft cloth or paper towel. Novus #2 plastic polish may be used to polish the barrel.
8. Examine the EPDM O-Rings and replace if they are hard, brittle, cracked, or flattened. Note that the red O-ring on the indicating float is a silicone rubber compound and is a metric size 17 x 1.
9. Re-assemble parts in reverse order taking care to not over-tighten screws (not more than 20 in-lbs of torque) as this may crack the barrel.

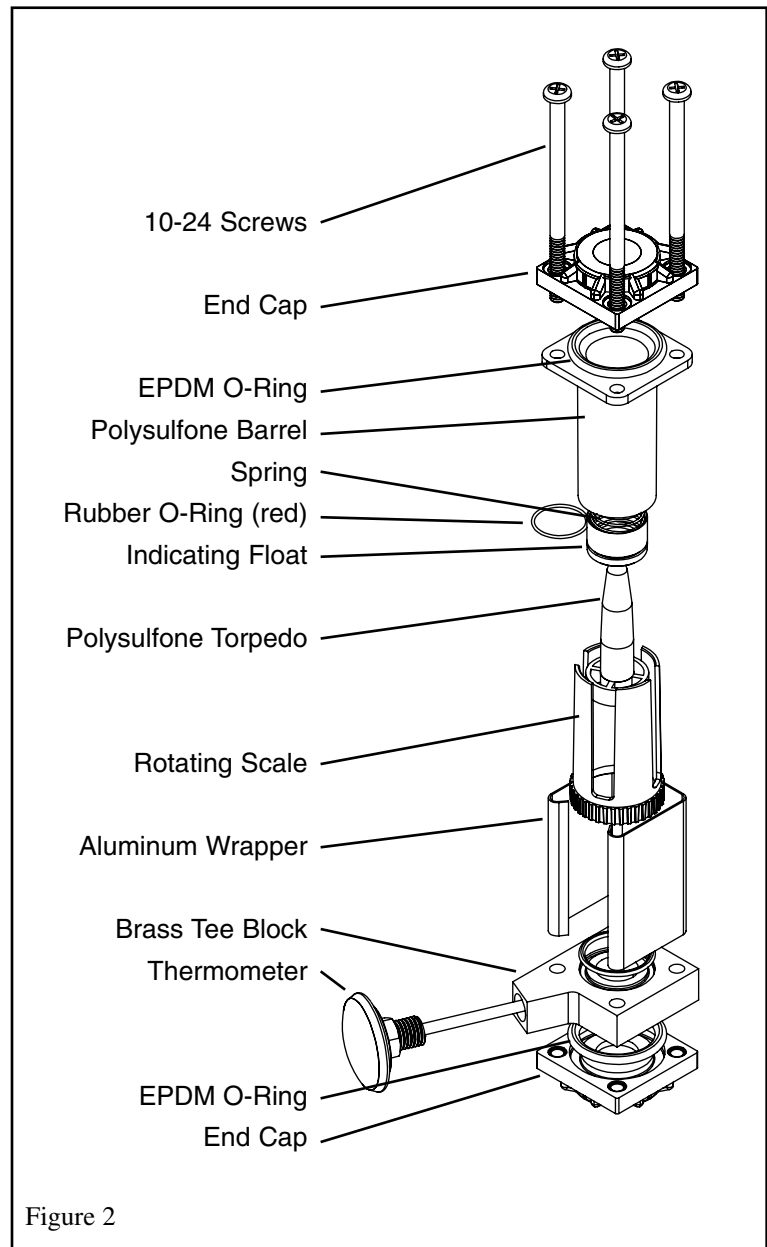

Tel: 888-792-2223, 508-842-1606
Fax: 508-842-4406 Email: sales@plastixs.com
Web: www.plastixs.com

Caution

- Use at temperatures above 130°F poses a serious personal injury hazard. Use extreme caution, protective clothing, or shielding around the system to minimize risk to personnel and nearby equipment.
- Accelerated chemical attack will result if flowmeters are used at elevated pressures and temperatures. Frequently inspect the body for cracking or crazing which may indicate chemical attack. Sudden failure and leakage can result from chemical attack. Consult the chemical compatibility list at right for substances that attack the polysulfone flowmeter body.
- Any liquid system offers the potential for accidental leakage. Leakage onto electrical or computer equipment could result in costly damage or personal injury. Do not locate piping systems where leakage might damage equipment or pose personal injury hazards. If it is impossible to avoid piping in such locations, use shielding to protect equipment and personnel.

Chemical Compatibility

The following is a list of chemicals that are not compatible with the UDEL Polysulfone used in the Smartflow small flowmeter. Contact Burger & Brown Engineering for more detailed information.

Acetone, Methyl Ethyl Ketone	Benzene
Carbon Tetrachloride	Chlorobenzene
Chloroform	Cyclohexanone
Esters	Freon TA
Methylene Chloride	Tetrachloroethylene
1,1,2,2-Tetrachloroethane	Toluene
1,1,1-Trichloroethane	Trichloroethylene
Xylene	

Please contact us for further information.



Tel: 888-792-2223, 508-842-1606

Fax: 508-842-4406 Email: sales@plastixs.com

Web: www.plastixs.com

Limited Warranty

Seller warrants that this product supplied will conform to the description herein stated and that the product will be of standard quality. This is the sole warranty made by Seller with respect to this product. Seller expressly disclaims any other express or implied warranties, including, but not limited to, the implied warranty of merchantability and the implied warranty of fitness for a particular purpose.

Seller shall not be liable for any cost or damages, whether direct, incidental or consequential, including, but not limited to, any injury, loss or damage resulting from the use of this product, regardless of whether any claim for such cost or damages is based on warranty, contract, negligence, tort or strict liability. The sole liability of Seller is limited to repairing or replacing this product.

this warranty shall not apply to any products that have been repaired or altered by anyone other than Seller. The warranty shall not apply to any products subject to misuse due to common negligence or accident, nor to any products manufactured by Seller which are not installed or operated in accordance with the printed instructions of Seller or which have been operated beyond the rated capacity of the goods. Seller states that the product's useful safe life is 5 years. Actual life may vary widely depending on operating environment such as temperature, pressure, and chemical exposure. Users are cautioned to refer to instructions for operating limits and a partial list of incompatible chemicals.