

U.S. Patent No. 5,813,601



### General Description

The **Smartflow Mold Temperature Regulator** effectively controls mold cooling water temperature between 80°F and 120°F (27° and 49°C) to maintain a steady mold temperature. Installed to control water flow exiting an injection mold, the Mold Temperature Regulator quietly recovers waste heat from the resin shot, working without electricity to reduce shop floor clutter, and cut production costs. In many cases, it is a simple, inexpensive substitute for a conventional electric mold heater.

*Cooling water temperature always corresponds to higher mold (steel) temperatures (for example: 120°F water temperature may result in 180°F mold temperature).*

### Turbulent Flow, Supply Cooling Water Pressure & Temperature

Traditionally, high turbulent flow rates are used in cooling water loops to achieve acceptable heat transfer rates from the mold. High turbulent flow rates are irrelevant when using the Smartflow Mold Temperature Regulator. It regulates cooling water flow leaving the mold to achieve Set Point temperature. The unit is also unaffected by supply cooling water pressure and temperature. For example, it automatically compensates for temperature changes of cooling tower water between night and day.

### Features and Benefits

- **Multiple zone control** - using several regulators or an optional inlet manifold facilitates effective zone control
- **Unaffected by pressure changes** - the Mold Temperature Regulator uses the thermal expansion principle for operation
- **Handles tower water temperature changes** - modulates flow to control cooling water temperature
- **In-Line mounting** - installs easily without additional hardware
- **Cost of ownership** - typically 1/6 the cost of a conventional electric mold heater
- **Maintenance free** - few internal parts for trouble-free operation
- **Energy saving** - it uses no electricity, conserving precious energy dollars
- **Small size** - cleans up shop floor clutter: no hoses or power cords to trip over
- **Integral dial thermometer** - verifies Set Point temperature
- **Optional inlet manifold** - provides temperature control for multiple zones with one regulator



# MOLD TEMPERATURE REGULATOR

## Principle of Operation

The Smartflow Mold Temperature Regulator works on the principle of thermal expansion. It is connected to the return lines of the mold cooling water loop. A simple bellows and range spring capsule senses the temperature of the water leaving the mold and compares it to the Set Point temperature. The Set Point is easily adjusted by rotating the pointer knob to the desired water temperature value on the calibration scale. The dial thermometer provides visual verification of the setting. Note: *A discrete cooling water temperature always corresponds to a hotter mold (steel) temperature.*

When the water temperature leaving the mold is hotter than the Set Point, the internal valve modulates

toward open, cooling water flow rate increases, and cooling water temperature decreases to stabilize at the Set Point. When the water temperature leaving the mold is cooler than the Set point, the internal valve modulates toward close, cooling water flow rate decreases, residency time in the mold increases and cooling water temperature rises until stabilizing at the Set Point. The valve never completely closes.

Note: The Mold Temperature Regulator recovers waste heat energy from the resin shot and transfers it to heat the cooling water and the mold. The Mold Temperature Regulator does not generate heat, and it does not function as a chiller.

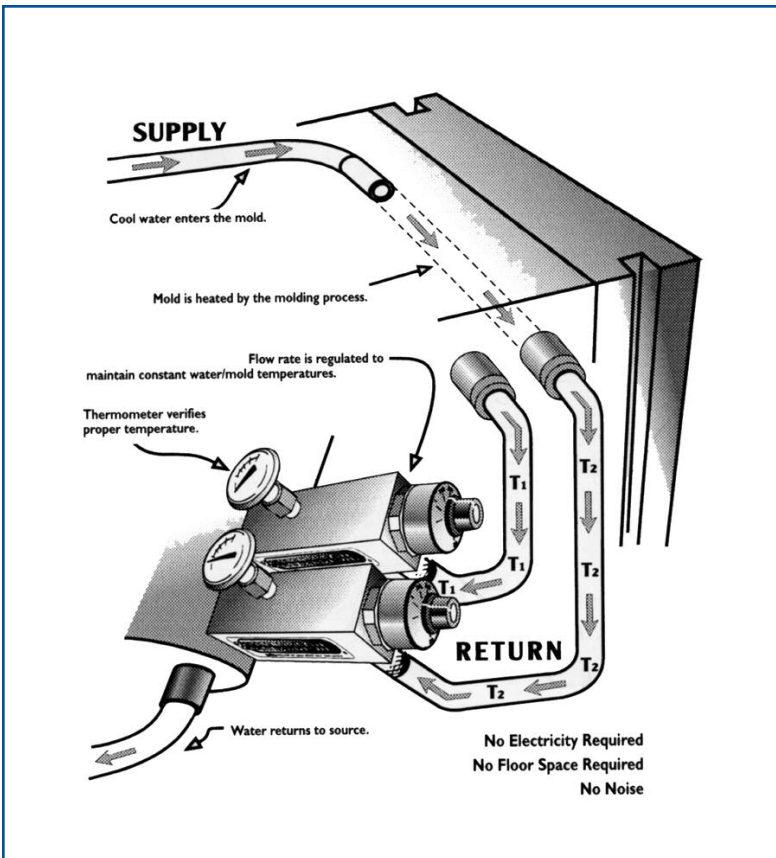

## Applications

The Mold Temperature Regulator is generally suitable for mold applications where the supply water is cooler than the mold and where the resin shot size is sufficient to heat the mold in the first few shots.

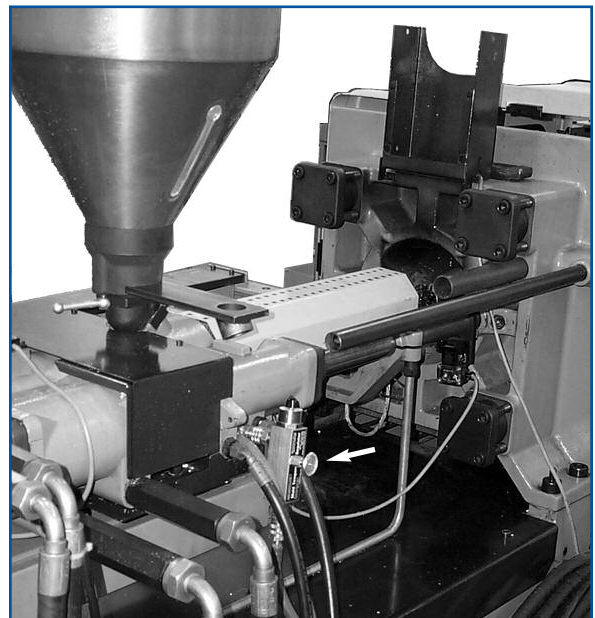

**Control Feed Throat Condensation** by installing a Mold Temperature Regulator in the barrel cooling loop. Set the dial once on the MTR, and allow it to maintain temperature and eliminate condensation in the resin.



151 Memorial Drive, Unit H  
Shrewsbury, MA 01545  
Tel: 888-792-2223, 508-842-1606  
Fax: 508-842-4406 Email: sales@plastixs.com  
Website: www.plastixs.com



# MOLD TEMPERATURE REGULATOR

## Model Numbers

Model	Inlet	Outlet
WDT2-N2-N4	1/4"NPT(F)	1/2"NPT(F)
WDT2-S2-P2	1/4" Quick Connect Socket	1/4" Quick Connect Plug
WDT2-S3-P3	3/8" Quick Connect Socket	3/8" Quick Connect Plug
WDT2-N2-N4-M	1/4"NPT(F) 7 port Manifold	1/2"NPT(F)
Manifold only WDMF-100	1/4"NPT(F) 7 port	

## Specifications

### Physical

Material.....All wetted parts are Electroless Nickel-Plated Brass & 303 Stainless Steel  
 O-Rings.....Buna-N  
 Inlet Size .....1/4" NPT(F)  
 Outlet Size .....1/2" NPT(F)  
 Maximum Pressure.....125 psi (8.6 bar)  
 Weight.....3 lbs (1.5 kg)

### Operating

#### Regulator

Cooling water set point range.....80° to 120°F  
 (27° to 49°C)

Accuracy.....±1°F  
 Flow capacity .....5 to 25 gallons (19 to 95 liters) per hour  
 Regulator operation is more accurate than dial thermometer.

#### Dial Thermometer

Range.....0 to 250°F  
 (-18 to 121°C)

Accuracy.....±1°F Mid Scale  
 ±2°F Full Scale

*Design and specifications are subject to change without notice.*

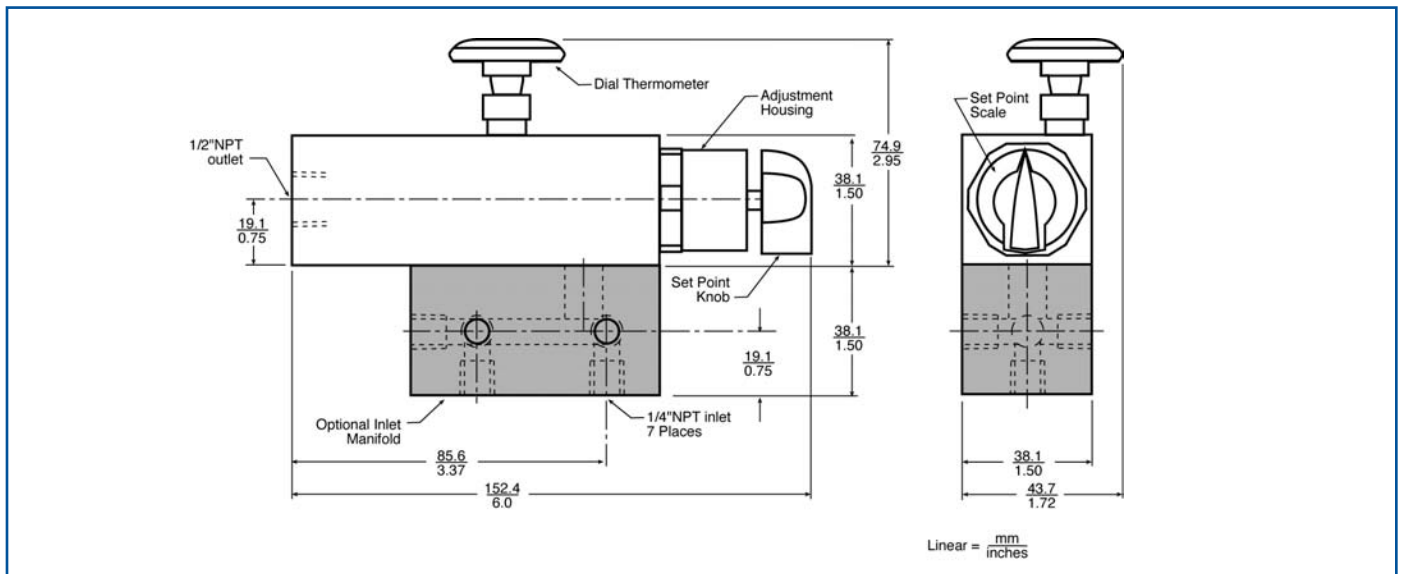



# MOLD TEMPERATURE REGULATOR

## Application Procedure

Use the following formula and method to calculate heat load for **one** cooling circuit. This will help determine suitability of the **Smartflow** Mold Temperature Regulator to your process.

1. Select material from the table at right and calculate BTU/hr using the formula below. Shot weight is the total drop including cold runner (if any).

$$\frac{\text{BTU/lb} \times \text{Shot Weight (oz.)} \times 225}{\text{Cycle Time (sec)}} = \text{BTU/hr}$$

2. Find BTU/hr along the X axis of the graph below. Locate the desired steel temperature along the Y axis of the graph. Find the spot where the X and Y values intersect.
3. The graphed line nearest this intersection point represents the difference in temperature between the incoming water and the Mold Temperature Regulator set point ( $\Delta T$ ).
4. The Smartflow Mold Temperature Regulator should work in your application if the sum of the incoming water temperature and the  $\Delta T$  value is between 80° and 120°F.

*Every mold is different! The effectiveness of the Mold Temperature Regulator relies on the ability of the resin shot to heat the mold, and the efficiency of the cooling lines inside the mold.*

*NOTE: These graphs and information are intended as a general guide for sizing and initial setup of the mold temperature regulator. Due to the different mold designs, results may vary from the graphs.*

### Typical Heat Values of Plasticized Resin\*

Material	BTU/lb
ABS .....	81
Acrylic .....	109
Nylon .....	183
Polycarbonate .....	112
Polyethylene - High Density .....	276
Polyethylene - Low Density .....	202
Polypropylene .....	291
Polystyrene .....	88
SAN .....	88

\*Total Heat Content + Latent Heat of Fusion

### Example:

A molder is using nylon material in a four-cavity mold with a shot weight of .90 ounces (including the runner). The cycle time is 12.5 seconds with a mold steel temperature of 180°F. BTU/hr formula is as follows:

$$\frac{183 \text{ BTU/lb} \times .90 \text{ oz.} \times 225}{12.5 \text{ sec}} = 2964.6 \text{ BTU/hr}$$

See the One Water Circuit Graph below left for the differential temperature ( $\Delta T$ ) value. Add 70°F incoming water temp. to the  $\Delta T$  value (20°F). This is the beginning set point for the mold temperature regulator, and may be adjusted as needed.

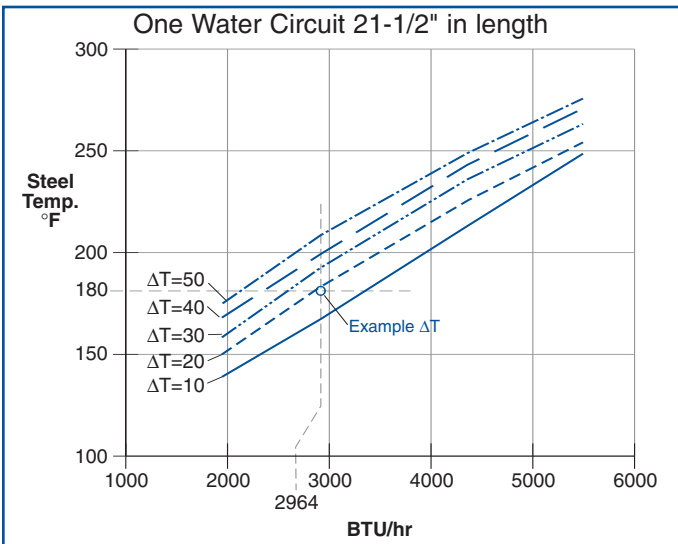

**Mold Temperature vs. Heat Input for 21-1/2" Water Circuit and Five Different Values of  $\Delta T$**

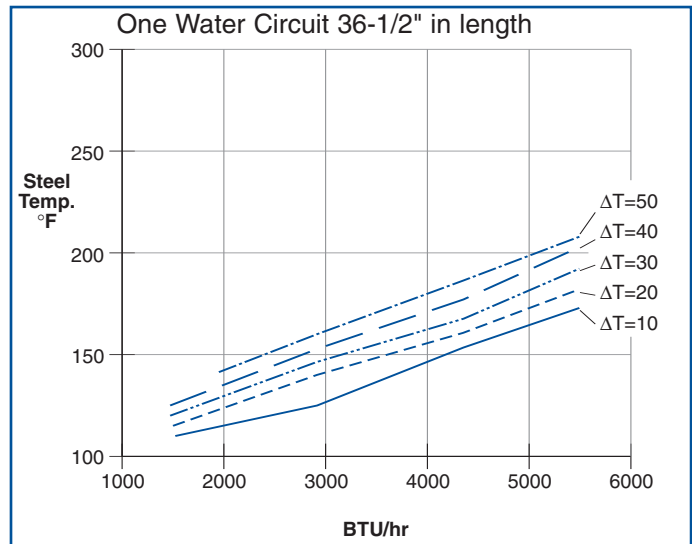

**Mold Temperature vs. Heat Input for 36-1/2" Water Circuit and Five Different Values of  $\Delta T$**

*These graphs were generated by simulated molds, with BTU input varied by electric heaters. The water line path through each mold was 7/16" diameter.*



151 Memorial Drive, Unit H  
 Shrewsbury, MA 01545  
 Tel: 888-792-2223, 508-842-1606  
 Fax: 508-842-4406 Email: sales@plastixx.com  
 Website: www.plastixx.com