

Pipe and Tube Bends for pneumatic systems, short and long radius

Tube Bending Capabilities

Pipe and tube bends of up to 180° are readily available in aluminum, stainless, carbon steel and galvanized in the sizes listed. Other centerline radii are available but not shown. Special shapes, 'U' bends, offsets, and bifurcated bends available upon request.

Morris tube bends are manufactured in our Knoxville, Tennessee, Plant.

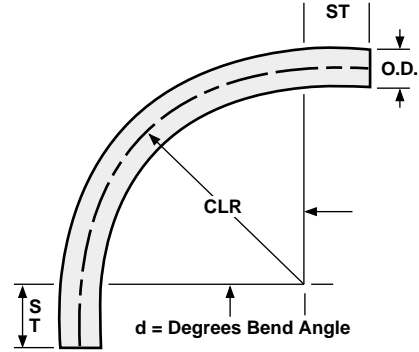

Morris Pipe and Tubing Straights



Straight lengths of pipe and tubing are available in carbon steel, aluminum, and stainless – 1-1/2" O.D. thru 10" pipe in a variety of wall thicknesses.

ORDER BENDS by O.D., wall thickness, alloy, degree of bend, centerline radius and tangent.

WALL THICKNESS: 16 ga. (.063), 14 ga. (.083), and 11 ga. (.120) in tubing. Schedules 5, 10 and 40 pipe. Other wall thicknesses on request.

*Carbon Steel, Schedule 40 Only.

MATERIALS: Aluminum is 6063-T1 extruded. Stainless is T304 ASTM A312 for Pipe and T304 ASTM A249 for tubing. Carbon steel ASTM A53 for pipe; A513 for tubing. Galvanized A53 for galvanized coated. Pipe and A513 for galvanized-coated tubing.

Tube Size	Pipe Size	Outside Diameter		Common Centerline Radii (CLR) Inches	Std. Tangent (ST)
		inches	mm		
1"		1.0	25.4	3, 4, 6, 12	4"
	1"	1.315	33.4	3, 5	4"
1-1/4"		1.25	31.8	3, 7.25	4"
	1-1/4"	1.660	42.2	3.5, 4, 6.25	4"
1-1/2"		1.5	38.1	2.5, 6, 7.5, 9, 12, 15, 18, 24, 30, 36	4"
1-3/4"		1.75	44.5	2.5, 8, 9, 12, 15, 24, 30, 36, 48	4"
	1-1/2"	1.9	48.3	5, 6, 7.5, 9, 10, 12, 18, 24, 30, 36, 48	4"
2"		2.0	50.8	2.5, 5, 6, 8, 8.5, 9, 10, 12, 15, 18, 24, 30, 36, 48	4"
2-1/8"		2.125	54.0	5, 12, 24, 30, 36	4-1/4"
2-1/4"		2.25	57.2	3, 9, 12, 15, 17, 24, 30, 36	4-1/2"
	2"	2.375	60.2	6, 7.5, 9, 10, 12, 15, 17, 24, 30, 36, 48	4"
2-1/2"		2.5	63.5	4, 6, 9, 12, 15, 17, 24, 30, 36, 48	5"
2-3/4"		2.75	69.9	17, 30, 36, 48	5-1/2"
	2-1/2"	2.875	73.0	12, 12.5, 15, 17, 24, 30, 36, 60	5"
3"		3.0	76.2	4.5, 7.5, 9, 10, 12, 15, 18, 24, 30, 36, 48, 60	6"
3-1/4"		3.25	82.6	17, 30, 36	6-1/2"
3-1/2"	3"	3.5	88.9	3.5, 6, 8.75, 12, 15, 16, 18, 24, 30, 36, 48	7" (6" - pipe)
3-3/4"		3.75	95.3	17, 24, 32, 36	7-1/2"
4"	3-1/2"	4.0	101.6	6, 10, 12, 16, 18, 20, 24, 30, 32, 36, 48, 60	8" (7" - pipe)
4-1/4"		4.25	107.9	16, 30, 36, 48, 60	8-1/2"
4-1/2"	4"	4.5	114.3	6, 9, 12, 16, 18, 20, 24, 30, 32, 36, 48, 60	9" (8" - pipe)
4-3/4"		4.75	120.7	36	9-1/2"
5"		5.0	127.0	7.5, 12.5, 17, 22, 24, 30, 36, 42, 48, 60	10"
	5"	5.563	141.3	15, 20, 24, 30, 36, 42, 48, 60, 72	10"
5-1/2"		5.5	139.7	30, 36	11"
6"		6.0	152.4	9, 15, 18, 24, 30, 36, 42, 48, 60, 72	12"
	6"	6.625	168.2	18, 24, 30, 36, 42, 48, 60, 72	12"
8"		8.0	203.2	12, 20, 32, 48, 60, 72	16"
	8"	8.625	219.1	24, 32, 40, 48, 60, 72	16"
	10"	10.75	273.1	40, 50	20"

Capabilities subject to change without notice.

TEES			WYES						LATERALS							
OD	A	B	OD	30° C	30° D	45° C	45° D	60° C	60° D	OD	30° E	30° F	45° E	45° F	60° E	60° F
2"	16"	8"	2"	8"	8"	8"	8"	8"	8"	2"	8"	16"	8"	16"	8"	16"
3"	16"	8"	3"	8"	8"	8"	8"	8"	8"	3"	10"	20"	8"	16"	8"	16"
4"	16"	8"	4"	8"	8"	8"	8"	8"	8"	4"	12"	24"	10"	20"	10"	20"
4-1/2"	18"	9"	4-1/2"	10"	10"	10"	10"	10"	10"	4-1/2"	12"	24"	10"	20"	10"	20"
5"	18"	9"	5"	11"	11"	11"	11"	11"	11"	5"	15"	30"	12"	24"	12"	24"
6"	20"	10"	6"	12"	12"	12"	12"	12"	12"	6"	18"	36"	15"	30"	15"	30"
8"	24"	12"	8"	14"	14"	14"	14"	14"	14"	8"	22"	40"	18"	36"	18"	36"

ORDER TEES by tube or pipe size, wall thickness, and metal.

O.D.s not listed, available on request.

ORDER LATERALS and WYES by tube or pipe size, wall thickness, metal and degree of angle.