

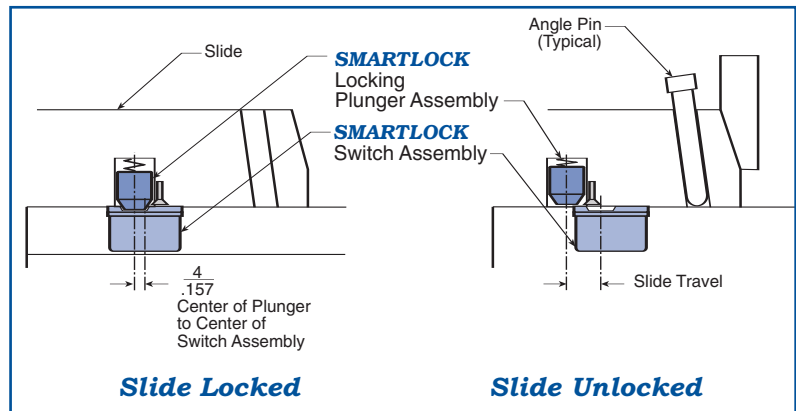

SMARTLOCK® SLIDE RETAINER AND LIMIT SWITCH

U.S. Patent No. 6,126,429

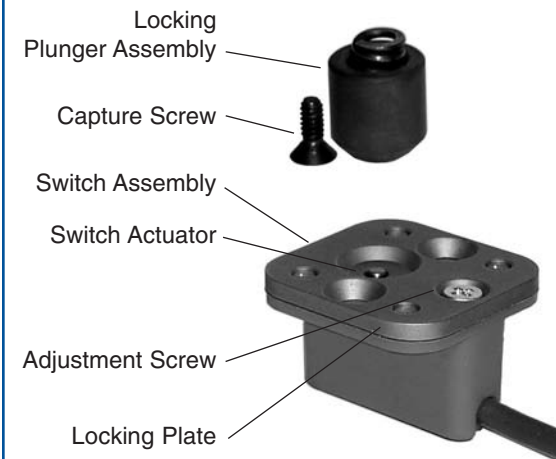

General Description

Smartflow **SMARTLOCK** slide retainer and limit switch is designed for injection molders to provide switching and a slide detent in one unique package. The **SMARTLOCK** locking function prevents premature slide movement during molded part ejection while the SPDT switch is simultaneously actuated.

The **SMARTLOCK** slide retainer and limit switch has been tested for reliability over 10 million cycles without failure. Two or more switches may be used for larger molds, or molds with multiple slides. Increased safety and prevention of mold damage result when the **SMARTLOCK** slide retainer and limit switch is installed in a mold. A capture screw holds the plunger in the slide to prevent loss.

Features and Benefits

- **Over 10 million cycle life** provides long dependable service.
- **17 - 27 pounds holding force**, adjustable
- **Capture screw** holds plunger in place to prevent loss.
- **175°F (79.4°C) standard temperature rating** allows installation into most molding applications.
- **250°F (121°C) high temperature unit** provides additional application flexibility.
- **Superior flush mount switch** is protected by mounting inside a milled pocket.
- **Stripped and tinned 6 ft. wire leads** make the switch ready to install without modification.

Specifications

Break Away Force* ...17 to 27 lbs. (adjustable)
 Electrical250VAC / 28VDC
4 Amps Inductive
5 Amps Resistive
 See chart below for temperature effects on maximum current rating

Operating Temperature

SL-222-CP175°F (79.4°C) max.
 SL-291-CP250°F (121°C) max.
 Switching.....SPDT

Rated Currents vs. Steel Temperature					
SL-222-CP			SL-291-CP		
Amps	°F	°C	Amps	°F	°C
5.0	85	29.4	5.0	100	37.7
4.0	120	49.0	4.5	155	68.3
3.0	155	68.3	4.0	210	98.8
2.0	175	79.4	3.5	250	121.1

The SmartLock switch is designed for use in very low power mold protection control circuits. It is not intended to switch heavy loads in power applications.

Materials

Switch BodyGlass-reinforced nylon
 Locking Plate.....Hardened Steel
 Locking Plunger.....Hardened Steel
 Wire Leads22ga stranded,
 3-conductor, shielded cable,
 6 ft. (1.8m) long,
 ends stripped and tinned



SMARTLOCK® SLIDE RETAINER AND LIMIT SWITCH

Model Number

SL-222-CP SmartLock slide retainer and limit switch with captive plunger (175°F / 79.4°C max.)

SL-291-CP High Temperature SmartLock slide retainer and limit switch with captive plunger (250°F / 121°C max.)

Replacement switches with small plunger
(.44"/11mm dia)

SL-222 SmartLock slide retainer and limit switch (175°F / 79.4°C max.)

SL-291 High Temperature SmartLock slide retainer and limit switch (250°F / 121°C max.)

Schematic Diagram

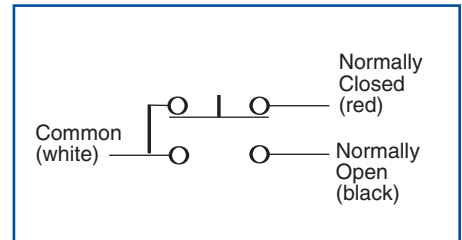

SmartLock Slide Retainer and Limit Switch is stocked and ready for same-day shipment.

Dimensions: SL-222-CP and SL-291-CP

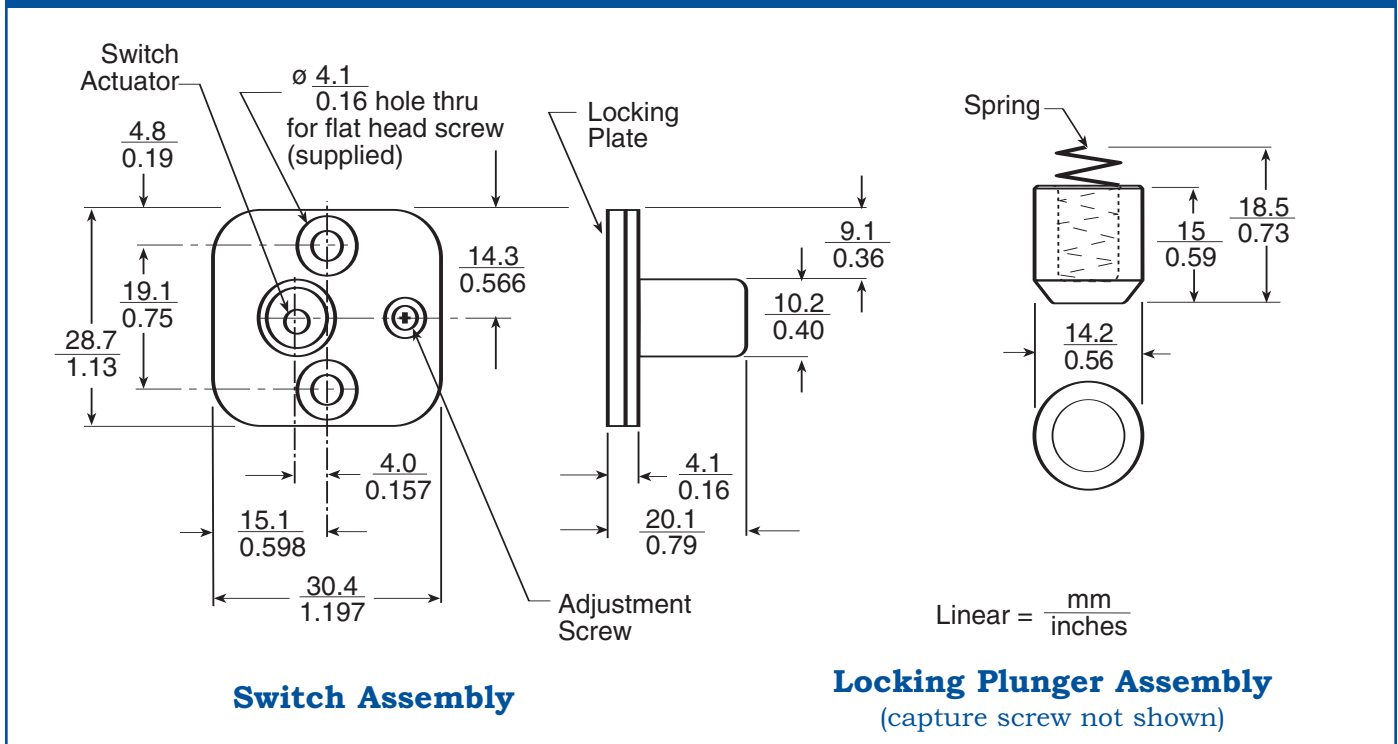

Parts shown actual size *Two and Three-Dimensional* part files are available for download from our web site at www.smartflow-usa.com.