

20"

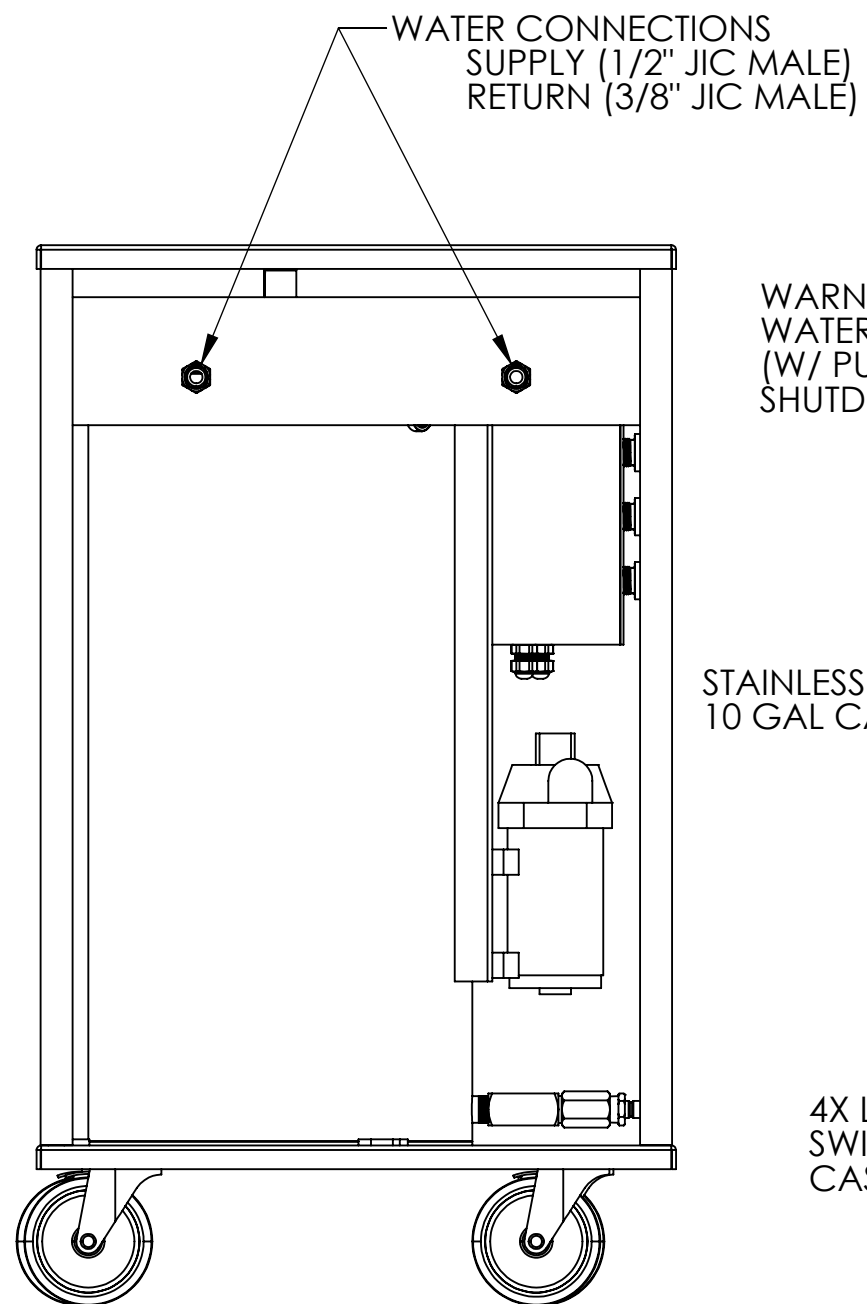

WATER CONNECTIONS  
SUPPLY (1/2" JIC MALE)  
RETURN (3/8" JIC MALE)

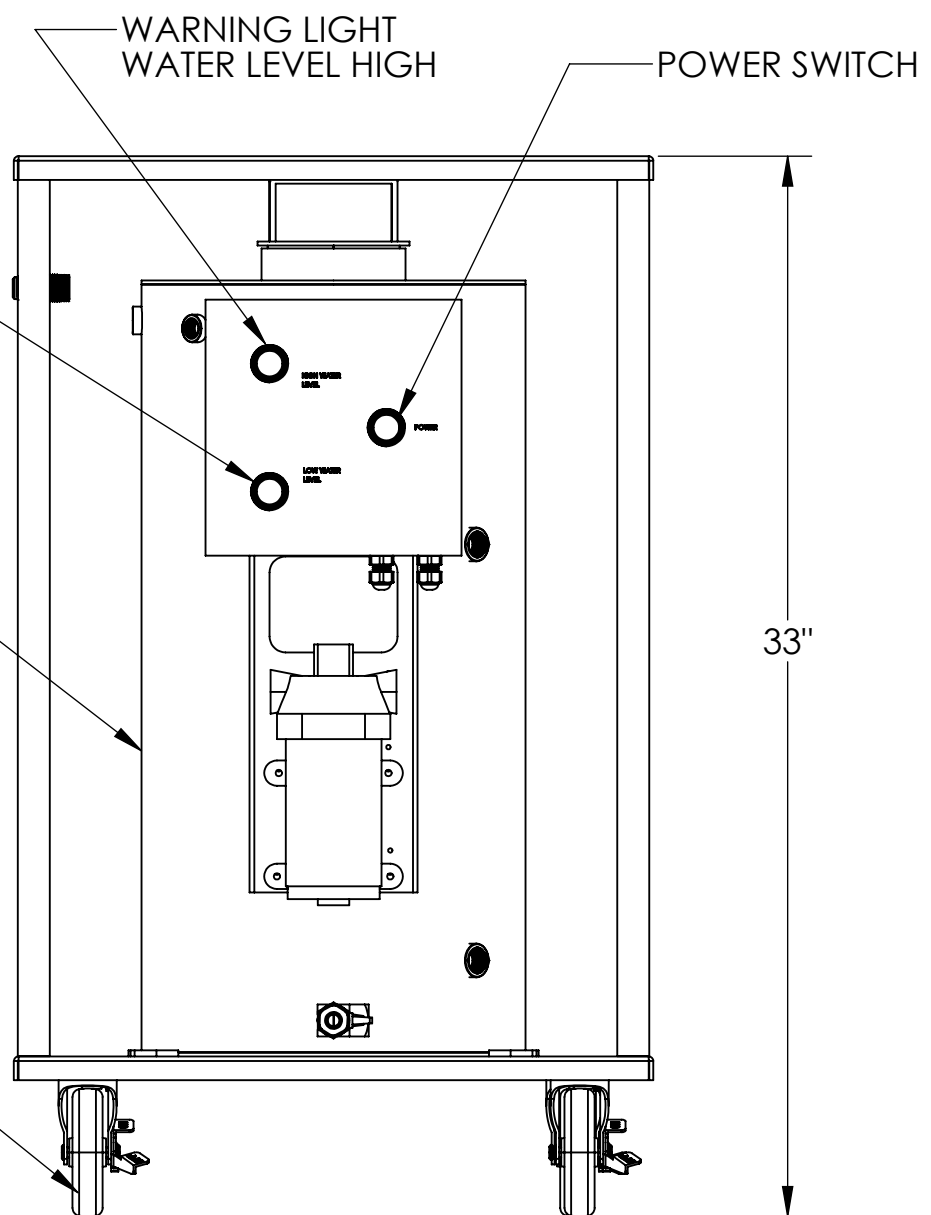

WARNING LIGHT  
WATER LEVEL HIGH

POWER SWITCH

WARNING LIGHT  
WATER LEVEL LOW  
(W/ PUMP  
SHUTDOWN)

STAINLESS STEEL, TANK  
10 GAL CAPACITY

33"

4X LOCKING  
SWIVEL  
CASTERS

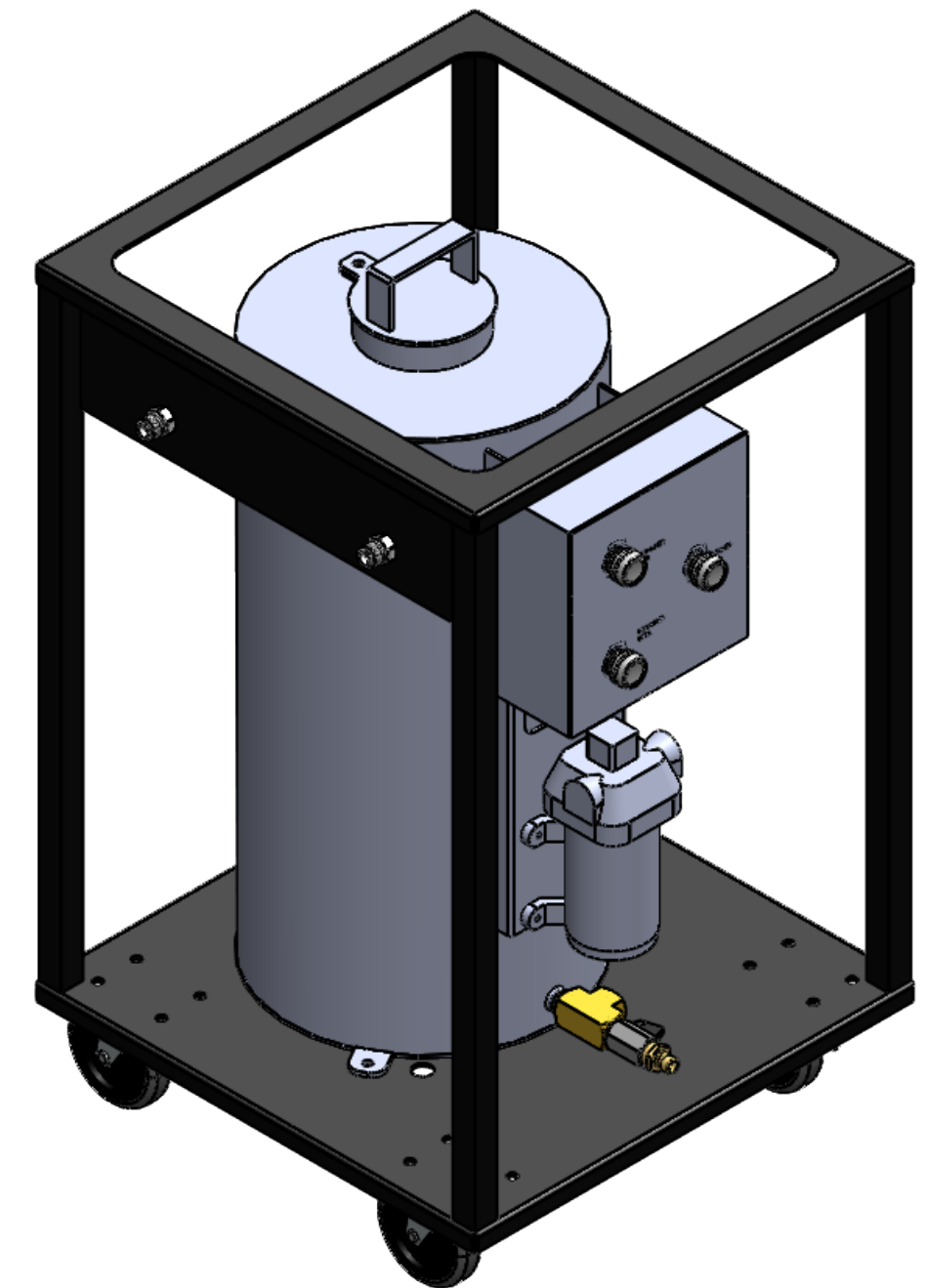

<b>plastiXs</b>		151 Memorial Drive Shrewsbury, MA 01545	
DRAWN BY <b>PJS</b>		DATE <b>10-30-2019</b>	
TITLE <b>SYSTEM WATER CART</b>			
MATERIAL <b>NOTED</b>			
FINISH			
UNLESS OTHERWISE SPECIFIED: 1. TOLERANCES: .XX ± .01 .XXX ± .005 FRACTIONAL ± 1/16 ANGULAR ± 1° 2. BREAK ALL EDGES AND DEBURR COMPLETELY. 3. NO NICKS, GOUGES OR SCRATCHES PERMISSIBLE. 4. ALL DIMENSIONS AND TOLERANCES APPLY AFTER FINISH.			THIRD ANGLE PROJECTION 
DRAWING NUMBER <b>PLX-X-PURE</b>	DRAWING REVISION <b>A1</b>	SCALE	PAGE <b>1</b> OF <b>1</b>