

AIRTECT

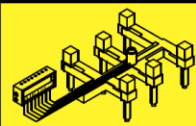

Plastic Leak Alarm System

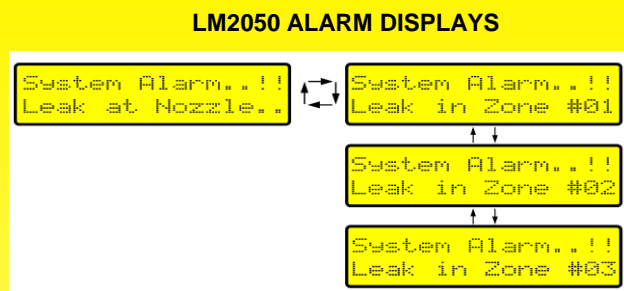
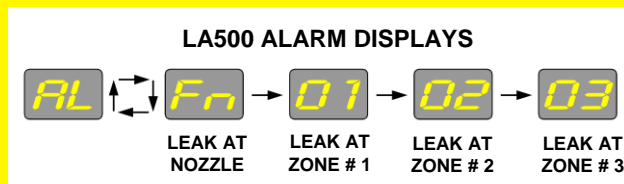
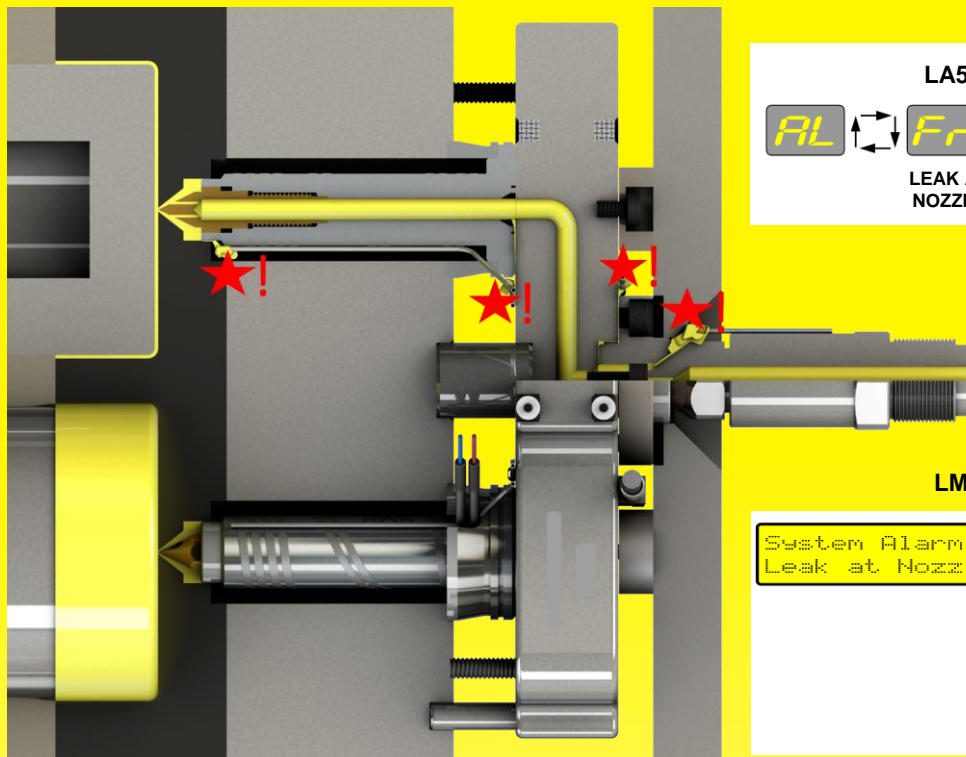

The AIRTECT Plastic Leak Alarm System is a unique device which gives protection against plastic leak damage caused by leaking plastic either within a Hot Runner Mold and/or at the IMM Injection Nozzle.

AIRTECT Systems are being used worldwide by many well known companies especially in Automotive and Medical Device manufacturing.

Whether you need to solve the problem of Plastic Leak Damage at the IMM Injection Nozzle and/or damage within a complex Hot Runner Mold, there is an AIRTECT Plastic Leak Detection Solution for you.

AIRTECT Systems are represented worldwide by a network of distributors and Plastixs, LLC is the distributor for North America. For more information, contact us at sales@plastixs.com or call 888-792-2223.

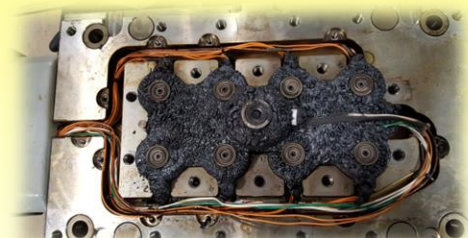
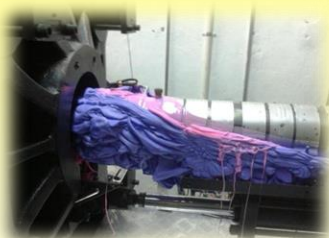

Plastic Leak Detection Solutions!

AIRTECT

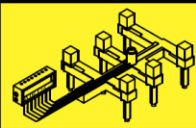

Plastic Leak Alarm System

Full range of SINGLE and MULTI-ZONE Leak Detection Modules!

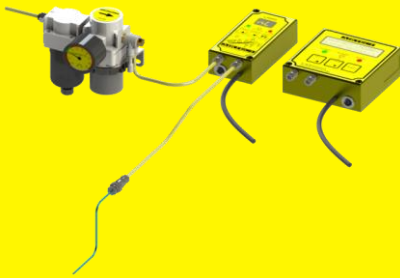

NOZZLE AND BARREL PROTECTION

**'NOZZLE' LEAK DETECTION
MODULES LA500 and LM2050**

Work as Single Zone IMM Nozzle Leak Detectors + Control/Display/Relay Interlock Modules for 'STANDARD' and 'MODULAR' Leak Detection Manifolds

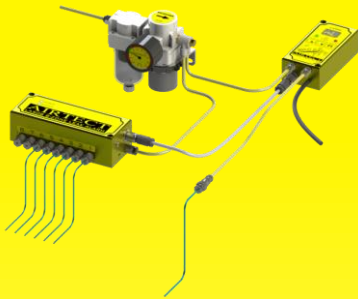

NOZZLE and HOT RUNNER MOULD PROTECTION

**'FIXED' and 'MODULAR' LEAK
DETECTION MANIFOLDS**

'FIXED' and 'MODULAR' Multi-Zone Leak Detection Manifolds are used with either an LA500 or LM2050 Control/Display/Relay Interlock Module

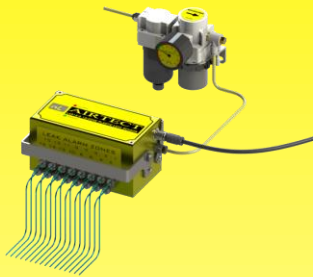

HOT RUNNER MOULD PROTECTION

**'FIXED' and 'MODULAR' STAND-ALONE
LEAK DETECTION MANIFOLDS**

'STAND-ALONE' Multi-Zone Leak Detection Manifolds have an integral Control/Display/Relay Interlock Module

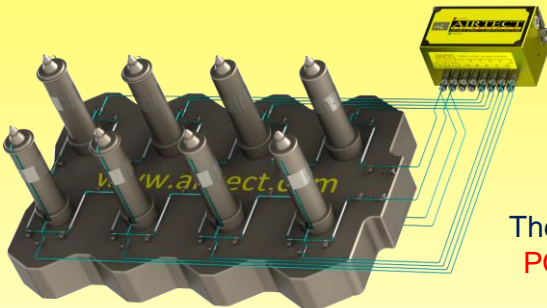

HOT RUNNER MOULD PROTECTION

'ULTIMATE'

**'FIXED' and 'MODULAR' STAND-ALONE
LEAK DETECTION MANIFOLDS**

The **ULTIMATE** range of Leak Detection Manifolds have both **POINT** and **CLOSED LOOP** Leak Detection Zones and are available as 'Stand-Alone' units only.

Detect Your NOZZLE and HOT RUNNER Leaks Early!

AIRTECT Distributor for North America:

plastixs[®]
manufacturing solutions

151 Memorial Drive, Unit H
Shrewsbury, MA 01545
888-792-2223

www.plastixs.com • sales@plastixs.com